

# 1814E with FilterQuick™

## Electric Fryer

### Wiring Diagrams

This manual is updated as new information and models are released. Visit our website for the latest manual.



8 1 9 7 3 2 0  
Part Number: FRY\_D\_8197320 11/2015

 **DANGER**

**Prior to movement, testing, maintenance and any repair on your Frymaster fryer, disconnect ALL electrical power from the fryer.**

# 1814 with FILTERQUICK™ SERIES ELECTRIC FRYER

## Table of Contents

---

### SECTION 1: Wiring Diagrams

1.1 Control Wiring .....	1-1
1.2 Contactor Box – Delta Configuration .....	1-2
1.3 Contactor Box – WYE Configuration .....	1-3



## 1.2 Contactor Box – Delta Configuration

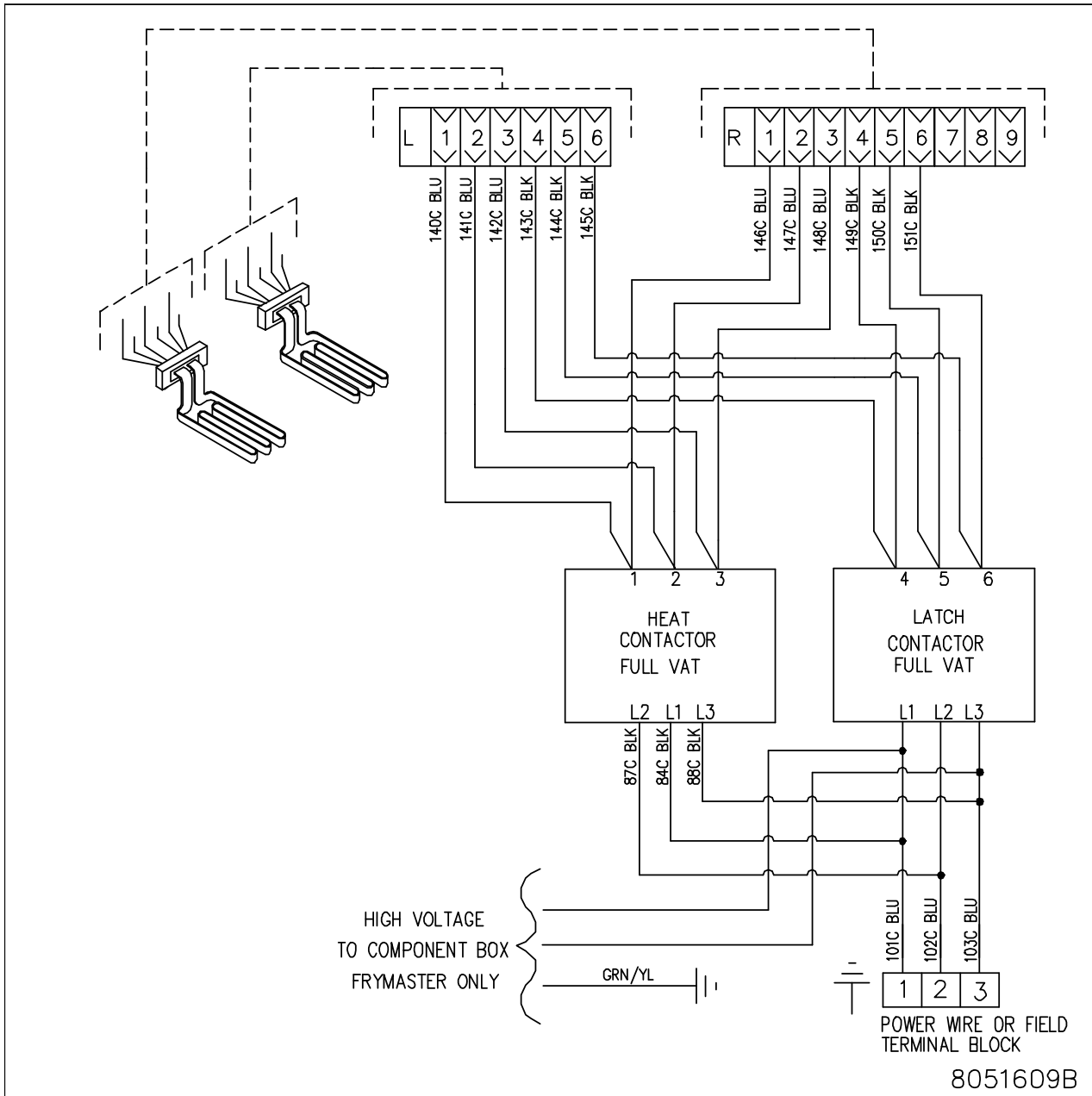

### 1.3 Contactor Box – WYE Configuration

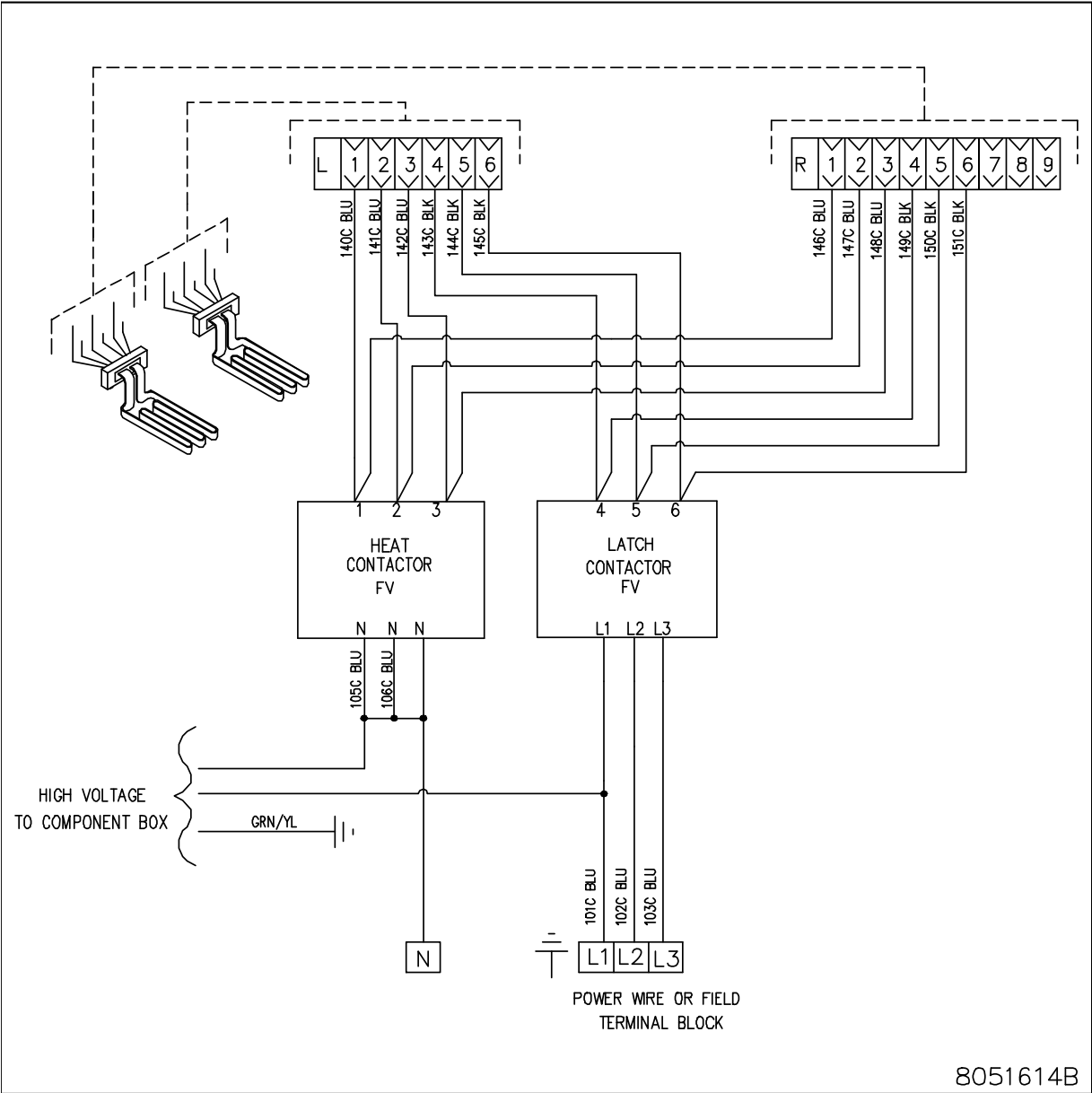

8051614B

**THIS PAGE INTENTIONALLY LEFT BLANK**



FRYMASTER  
8700 LINE AVENUE, SHREVEPORT, LA 71106-6800

318-865-1711  
844-724-CARE (2273)  
[WWW.FRYMASTER.COM](http://WWW.FRYMASTER.COM)  
EMAIL: [SERVICE@FRYMASTER.COM](mailto:SERVICE@FRYMASTER.COM)



Every new piece of Manitowoc Foodservice equipment comes with KitchenCare™ and you choose the level of service that meets your operational needs from one restaurant to multiple locations.

**StarCare** – Warranty & lifetime service, certified OEM parts, global parts inventory, performance audited

**ExtraCare** – CareCode, 24/7 Support, online/mobile product information

**LifeCare** – Install & equipment orientation, planned maintenance, KitchenConnect™, MenuConnect

**Talk with KitchenCare™** - 1-844-724-CARE - [www.mtwkitchencare.com](http://www.mtwkitchencare.com)



To learn how Manitowoc Foodservice and its leading brands can equip you, visit our global web site at [www.manitowocfoodservice.com](http://www.manitowocfoodservice.com), then discover the regional or local resources available to you.

